

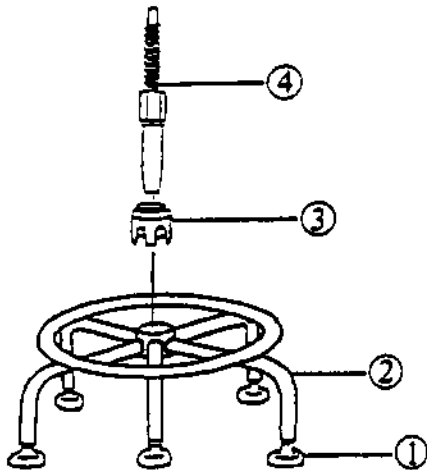

# Assembly Instructions for "STANDARD" Chair No. DC888

## PARTS LIST

KEY	QTY	DESCRIPTION	KEY	QTY	DESCRIPTION	KEY	QTY	DESCRIPTION
1	5	GLIDE	7	6	M6xØ14x20mm MACHINE SCREW	12	1	BACKREST POST + PLASTIC COVER
2	1	BASE	8	1	KNOB FOR IN & OUT	13	1	PLASTIC HOLDER
3	1	BASE COVER	9	1	FLAT WASHER	14	1	STEEL PLATE
4	1	SEAT POST	10	1	LOCK WASHER	15	2	BACKREST SCREW
5	1	SEAT	11	1	BACKREST	16	1	PLASTIC COVER



### STEP 1.

- Insert (1) glides into (2) base. Place (3) base cover on (2) base. Insert (4) seat post into (2) base.

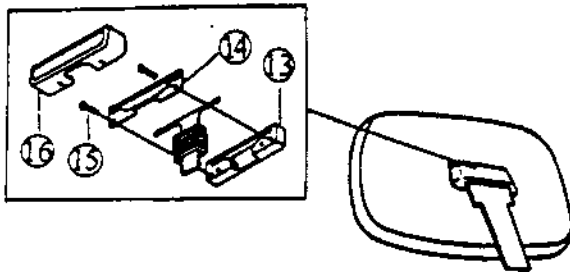

### STEP 2.

- Place (13) plastic holder on (11) backrest aligning holes. Push (12) backrest post + plastic cover (TOP) to (13) plastic holder. Attach (14) steel plate and (13) plastic holder to (11) backrest with (15) backrest screws. Snap (16) plastic cover on (13) plastic holder.

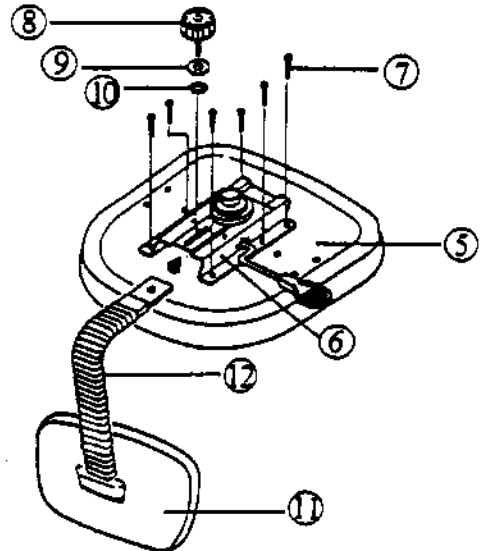

### STEP 3.

- Align (6) mechanism to back of (5) seat and screw-in with (7) M6xØ14x20mm machine screws. Insert (12) backrest post + plastic cover into (6) mechanism. Securely tighten with (8) knob for in & out and (9) & (10) flat and lock washers. Adjust to desired position.

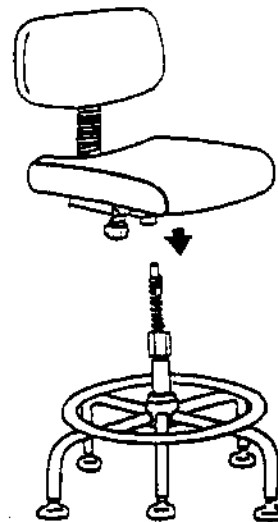

### STEP 4.

- Place upper assembled portion of chair into (3) seat post.

Made in Taiwan

